

Emerging Technologies

A New Exhibit Section at the Clinical Lab Expo

Background

AACC's Clinical Lab Expo is the largest In Vitro diagnostics event in the world. Not only is it the annual meeting place for laboratory professionals from around the world to meet with IVD vendors, but it has become the most important business to business venue for our industry, as well as the venue for the introduction of new technologies and lab processes. At the request of a number of start-up companies that need a showcase for their developments the 2007 Clinical Lab Expo will have a new section on the exhibit floor: "Emerging Technologies."

The Purpose

The area will be available to companies, institutions, start-ups and individuals to introduce new, non-commercialized technologies to:

- Outsource/acquire intellectual property for possible commercial development
- Develop collaboration with other companies
- Create awareness of new technology concepts
- Develop private equity relationships

Emerging Technologies Section

The area on the exhibit floor will be centrally located and will consist of a series of three-sided kiosks. Each exhibit space (one side of a kiosk) will be space 36" wide x 96" tall to describe the intellectual property or product concept. It will include a rack to hold printed material. A bar stool will be provided for each space. Each panel will include Velcro compatible covering, 2-plex literature holders, and a high stool.

The area will be carpeted and vacuumed daily. Exact size of the area will be determined by contracts received, but to accommodate the minimum requirement of 15 participants (5 kiosks), an area of approx 20' x 30' will be dedicated to the Emerging Technologies Section. Several 22" x 28" signs in easels/holders would identify the area. Participants may order electrical service and Internet access at the published rates in the exhibitor manual, but no additional furniture will be permitted.

Cost

Each exhibit space will cost \$1,600 fee. Additional panels may be rented at the same rate of \$1,600 per panel (maximum of 3 per organization).

Criteria for Inclusion

Below are the criteria for inclusion:

- The intellectual property/concept/product must relate to the IVD industry
- The "product" cannot currently be in commercial distribution.

PR Support

Company information and a brief description of the intellectual property will appear in the *Exhibit Guide* and, the *Clinical Lab News Convention Dailies*, plus announcements to appropriate market sectors. (Subject to when commitments are received.)

About the AACC Clinical Lab Expo (San Diego, July 17-19, 2007)

The Expo focuses on the IVD industry and is the largest of its kind in the world. It consists of 650 companies occupying approx 1,800 booths and is attended by 20,000 clinical lab scientists and industry executives. More information can be obtained at www.scherago.com/cle.

Kiosk Contract: 2007 Emerging Technologies

Display Details

The Clinical Lab Expo will provide a "kiosk" consisting of three panels, each panel will be 8' H x 3' W set in a triangular base. Participant will have access to one panel for a \$1,600 fee. In the case of organizations with more than one ET concept, additional panels may be rented at the same rate of \$1,600 per panel (maximum of 3 per organization). Each panel will include velcro-compatible covering, 2 plexiglas literature holders, and include a high stool. The area will be carpeted and vacuumed daily. Exact size of the area will be determined by contracts received, but to accommodate the minimum requirement of 15 participants (5 kiosks); an area of approx 20' x 20' is projected for this pilot program. Several 22" x 28" signs in easels/holders will identify the area. Participants may order electrical service and Internet access at the established rates in the Exhibitor Service Manual, but no additional furniture will be permitted. [The Clinical Lab Expo reserves the right to cancel the Emerging Technologies section should there be a lack of participation. If this occurs, the full \$1,600 fee will be refunded. This is the full extent of the Expo's responsibility if the program is cancelled. Should the technology be purchased or acquired and the company no longer wishes to be in the Emerging Technologies section, paid fee(s) will be transferred to the cost of a booth on the exhibit floor.]

Participant names and titles of the emerging technologies will be published in the Clinical Lab Expo *Exhibit Guide* if appropriate deadlines are met by the participants.

- I wish to reserve 1 panel at \$1,600 (for more than one kiosk, submit additional contract-maximum of three kiosks per company)
- Please check if you require a proforma invoice

Company/Organization Name: _____

Address: _____

City/State/Province: _____

Postal Code/ Country: _____

Contact Name: _____

Phone: _____

Fax: _____

Email: _____

Product description (50 words or less)—please submit by email to tonym@schicago.com.

Payments by credit card are not accepted. **Please make checks payable to American Association for Clinical Chemistry.** Payment must be drawn on a US bank in US dollars. For a proforma invoice or information on bank payment by electronic funds transfer, contact Ms. Jackie Diaz as jackied@schicago.com.

Contracts and checks should be sent to American Association for Clinical Chemistry, c/o Scherago International, 525 Washington Blvd., Suite 3310, Jersey City, NJ 07310. Phone 201.653.4777 Fax 201-653-5705

1M TRIANGULAR KIOSK

Qty	Type	Description	Size
3	P60	8'-0"	96"
3	H45	1 Meter	37-9/16"
3	H200	1 Meter	37-9/16"
A 3	Standard Panel	1M x 8' Panel	38-1/8" x 87"
6	Misc. Parts	Lit. Pocket	Standard

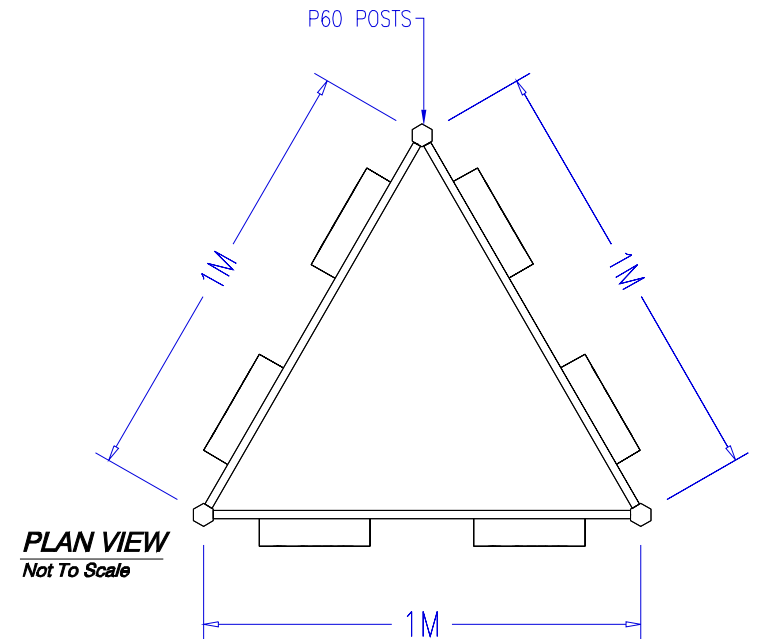
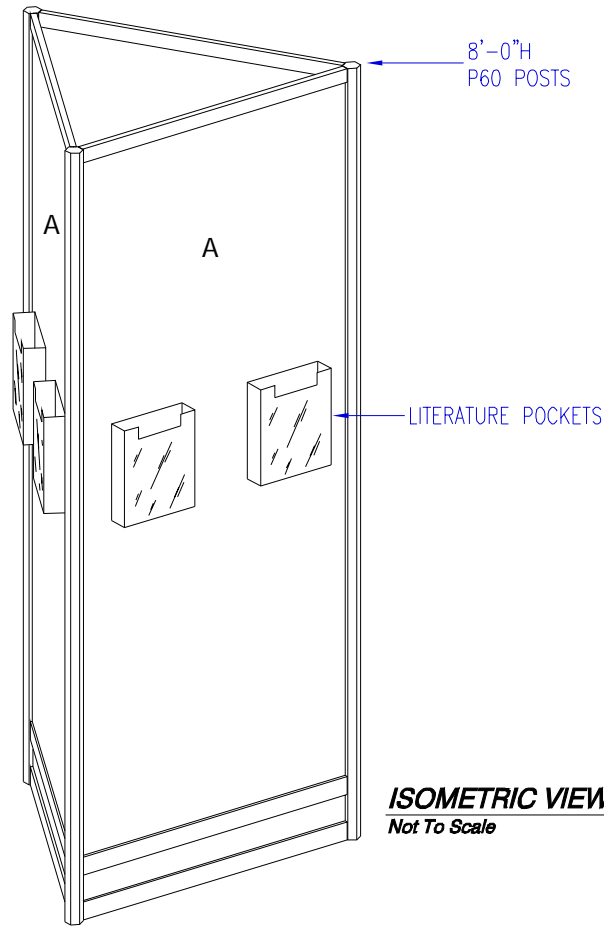

Show Name: AACC 2007

Show Location: SAN DIEGO CONVENTION CENTER

Show Dates: JULY 2007

Account Executive: JOHN THORPE

Job Number: 28-072194

File Name: 1M KIOSK-AACC07-A.dwg

Drawn By: ADAM GONDEK - CHICAGO

Date: 02/09/07

Revised: 00/00/00

PAGE 1 OF 1

F R E E M A N

ALL IDEAS, DESIGNS AND ARRANGEMENTS REPRESENTED BY THIS DRAWING WERE CREATED BY FREEMAN FOR USE ON THE SPECIFIED PROJECT, AND REMAIN THE PROPERTY OF SAID COMPANY.
NONE OF SUCH IDEAS SHALL BE USED OR DISCLOSED TO ANY PERSON, FIRM OR CORPORATION FOR ANY PURPOSE WITHOUT WRITTEN PERMISSION OF FREEMAN.